

# Munters Euroemme EC

## Air extraction fans

The EC series is one of the most renowned cone fan families, delivering exceptional performance in livestock farming (broiler, layer, swine, dairy) as well as greenhouse applications.

### Benefits

- Superior durability with M-Protect coating
- Fast and easy installation
- High airflow capacity
- Energy efficient solution, the EC50 E-line version saves up to 50% on electricity costs
- Suited for tunnel ventilation, especially in large structures



EC50 E-line

The EC 50-52 exhaust cone fans are the ideal choice for large livestock houses and greenhouses, meeting the growing demand for higher power and long-lasting reliability. Thanks to their peculiar cone and propeller design, EC fans ensure high airflow capacity and low energy consumption.

The housing, cone, conveyor, and shutters are made of M-Protect coated steel for greater strength and resistance against corrosion. Central hub and V-belt pulley are made of die-cast aluminum.

The patented centrifugal system provides an energy efficient solution and powerful springs keep shutters tightly closed when the fan is not turned on, avoiding air leakage and blocking light. The EC50 E-line model reduces power consumption by up to 50% compared to the same fan with AC motor, while enabling speed regulation.

The cone is made up of four detachable sections that can be quickly and easily assembled on site, significantly reducing transportation volume and costs. In addition, the EC52 cone features a space-saving design that optimizes installation, especially when multiple fans are mounted on the same wall.

As the market leader in ventilation solutions for more than 60 years, GrainProteinTech Climate Control & Air Treatment guarantees quality and is ISO 9001 certified.

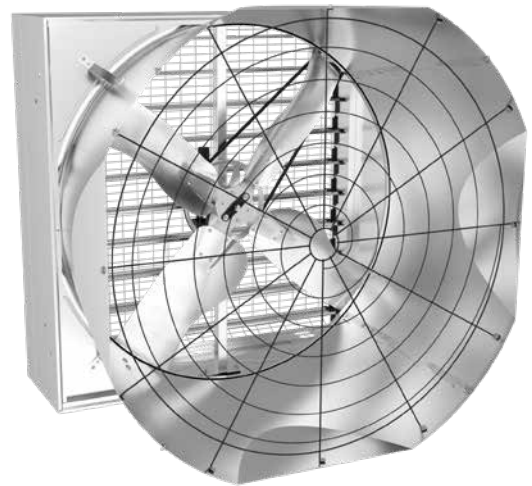

EC52



Proudly manufactured with 100% renewable energy in our plants in Italy

## Future-proof your farm with EC50 & EC52 Erp

Ready for the new European ErP Regulation.

The EC ErP-compliant models combine superior cone fan performance with EU efficiency requirements to maximize your efficiency.

- Full CE compliance: secure your farm with our certified fans.
- Tuned for robustness: optimized motor and propeller.
- Built for large scales: the ideal choice for tunnel-ventilated farms.

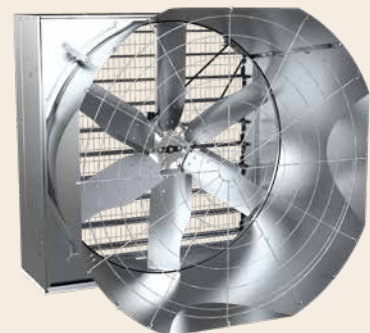

# Munters Euroemme EC50

## AC motor

### Dimensions

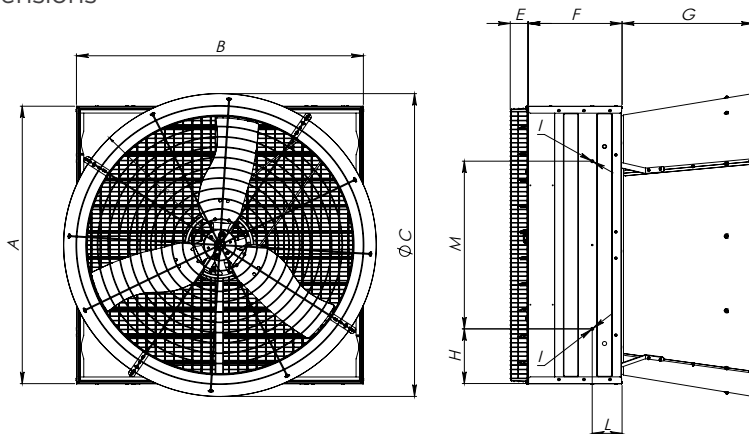

	EC50
A	1380 mm
B	1380 mm
C	1500 mm
D	-
E	90 mm
F	450 mm
G	630 mm
H	275 mm
I	M8
L	143 mm
M	830 mm

### Technical specifications

		EC50 Belt 1.0	EC50 Belt 1.5
Nominal power	hp [kW]	1.0 [0.75]	1.5 [1.1]
Propeller diameter	mm [inch]	1270 [50]	
Number of blades/material		3/M-Protect	
Number of shutter blades		10	
Motor/drive type		AC/Belt	
Weight of fully equipped fan	kg	106	108
Max power consumption/max current <sup>1</sup>	W/A	960/2.1	1550/3.3
Max operating temperature	°C [°F]	50 [122]	
Max operating pressure	Pa	50	
Motor insulation grade/protective class		F/IP55	
Noise level <sup>2</sup>	Db(a)	69.7	75.2

<sup>1</sup>50 Hz 400 V specification, 60 Hz available upon request, <sup>2</sup>Noise measure made according to ISO 3744

#### Airflow

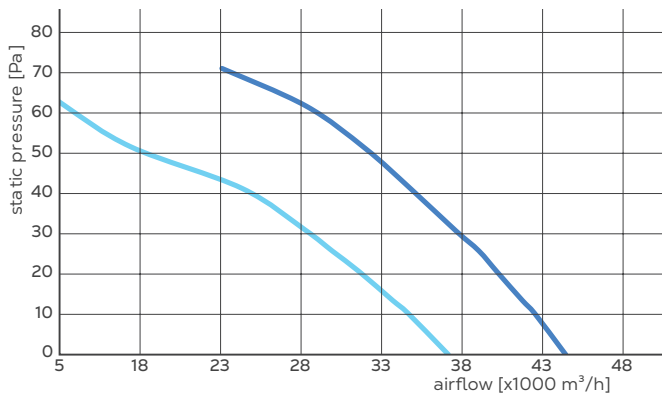

#### Efficiency

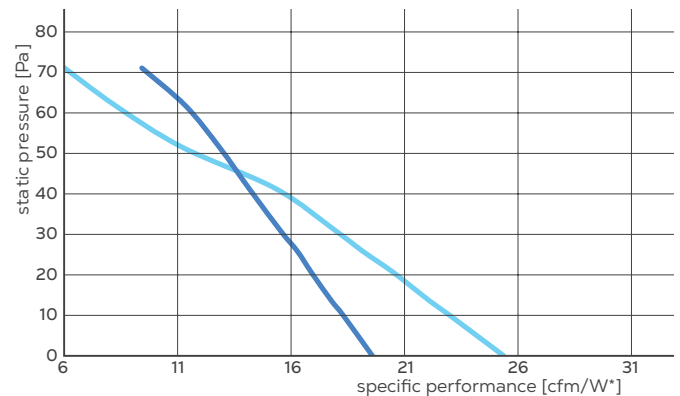

EC50 Belt 1.0

— IE1 1.0 hp

EC50 Belt 1.5

— IE1 1.5 hp

Airflow and efficiency tested in the test chamber in accordance with ANSI/AMCA 210/15 Standard, certified by BESS Lab. \*1 cfm/W = 1.7 (m³/h)/W

### Load capacity

	EC50 Belt 1.0/1.5	
	Unassembled	Assembled
40' HC container	220	39
13.6 m truck	-	44

Pyramidal mesh for installation below 2.7 m available upon request.

# Munters Euroemme EC50

## Erp

### Dimensions

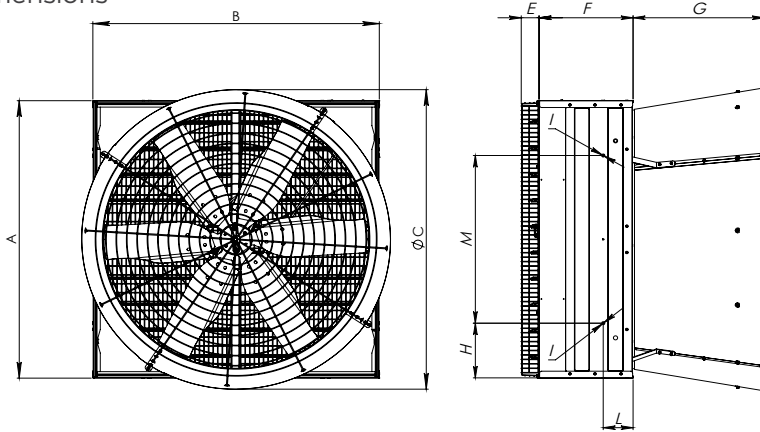

	EC50
A	1380 mm
B	1380 mm
C	1500 mm
D	-
E	90 mm
F	450 mm
G	630 mm
H	275 mm
I	M8
L	143 mm
M	830 mm

### Technical specifications

		EC50 Erp
Nominal power	hp [kW]	2.0 [1.5]
Propeller diameter	mm [inch]	1265 [50]
Number of blades/material		6/M-Protect
Number of shutter blades		10
Motor/drive type		AC/Belt
Weight of fully equipped fan	kg	110
Max power consumption/max current <sup>1</sup>	W/A	2318/4.5
Max operating temperature	°C [°F]	50 [122]
Max operating pressure	Pa	90
Motor insulation grade/protective class		F/IP55
Noise level <sup>2</sup>	Db(a)	75.3

<sup>1</sup>50 Hz 400 V specification, 60 Hz available upon request, <sup>2</sup>Noise measure made according to ISO 3744

Airflow

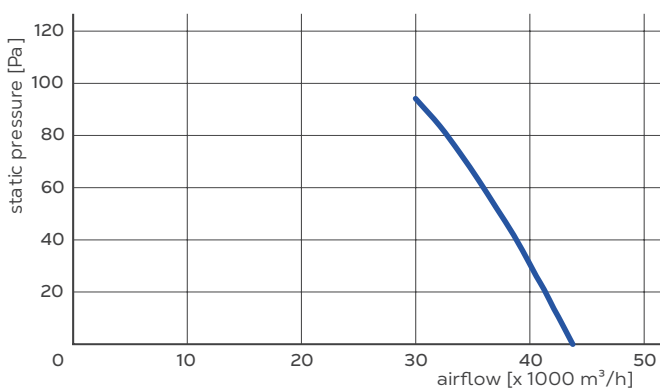

Efficiency

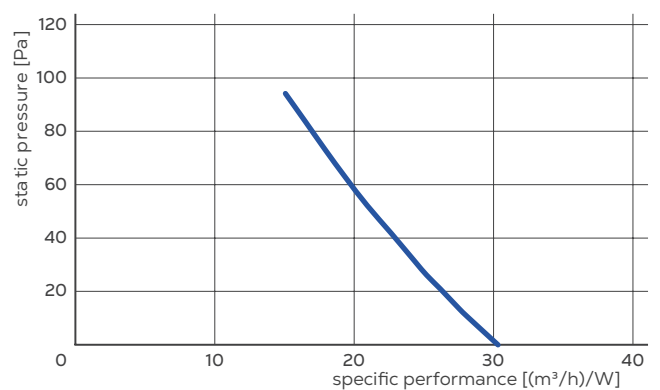

— EC50 Erp IE3

Airflow and efficiency tested in the test chamber in accordance with ANSI/AMCA 210/15 Standard, certified by BESS Lab.

### Load capacity

	EC50 Erp	
	Unassembled	Assembled
40' HC container	220	39
13.6 m truck	-	44

Pyramidal mesh for installation below 2.7 m available upon request.

# Munters Euroemme EC50

## E-line

### Dimensions

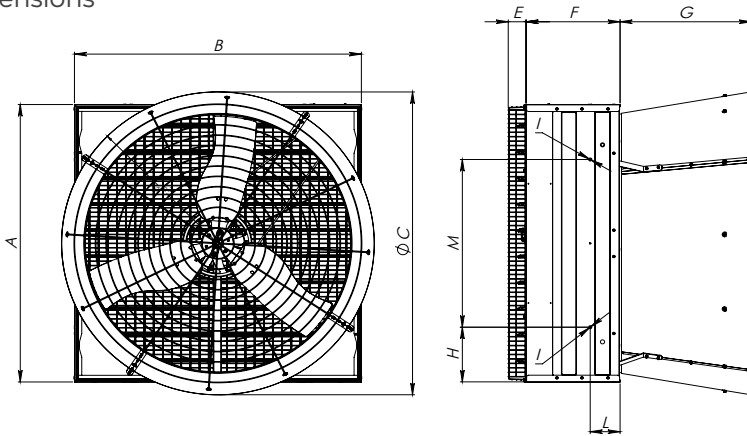

	EC50
A	1380 mm
B	1380 mm
C	1500 mm
D	-
E	90 mm
F	450 mm
G	630 mm
H	275 mm
I	M8
L	143 mm
M	830 mm

### Technical specifications

		EC50 E-line
Nominal power	hp [kW]	1.6 [1.2]
Propeller diameter	mm [inch]	1270 [50]
Number of blades/material		3/M-Protect
Number of shutter blades		10
Motor/drive type		EC/Belt
Weight of fully equipped fan	kg	109
Max power consumption/max current <sup>1</sup>	W/A	1600/3.1
Max operating temperature	°C [°F]	50 [122]
Max operating pressure	Pa	50
Motor insulation grade/protective class		H/IP66
Noise level <sup>2</sup>	Db(a)	75.1

<sup>1</sup>400 V specification, <sup>2</sup>Noise measure made according to ISO 3744

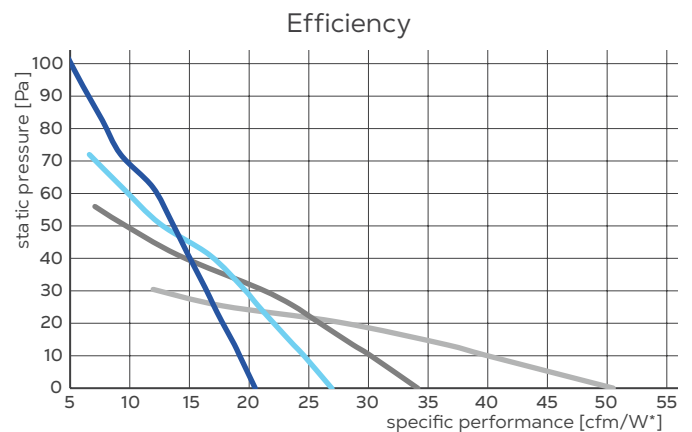
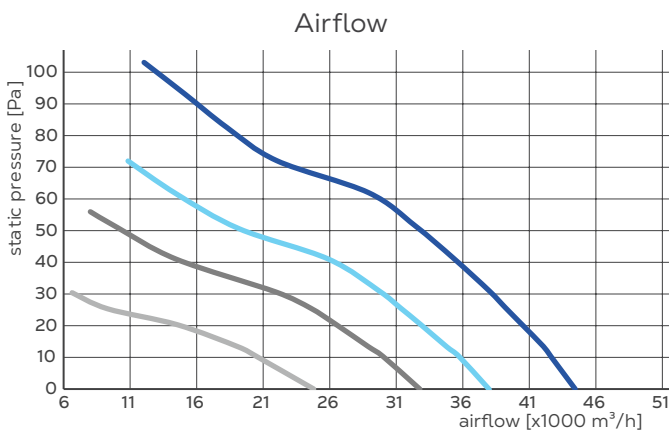

### EC50 E-line

— 504 rpm      — 427 rpm      — 366 rpm      — 260 rpm

Airflow and efficiency tested in the test chamber in accordance with ANSI/AMCA 210/15 Standard, certified by BESS Lab. \*1 cfm/W = 1.7 (m³/h)/W

### Load capacity

	EC50 E-line	
	Unassembled	Assembled
40' HC container	220	39
13.6 m truck	-	82

Pyramidal mesh for installation below 2.7 m available upon request.

# Munters Euroemme EC52

## AC motor

### Dimensions

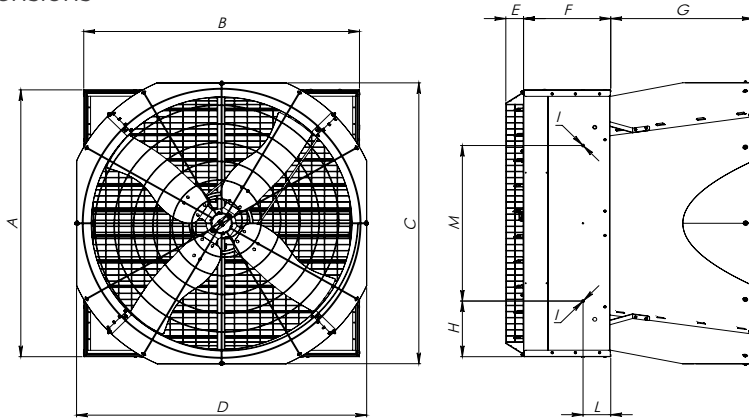

	EC52
A	1425 mm
B	1425 mm
C	1500 mm
D	1500 mm
E	95 mm
F	450 mm
G	740 mm
H	298 mm
I	M8
L	143 mm
M	830 mm

### Technical specifications

		EC52 Belt 1.0	EC52 Belt 1.5	EC52 Belt 2.0
Nominal power	hp [kW]	1.0 [0.75]	1.5 [1.1]	2.0 [1.5]
Propeller diameter	mm [inch]	1335 [52]		
Number of blades/material		4/M-Protect		
Number of shutter blades		10		
Motor/drive type		AC/Belt		
Weight of fully equipped fan	kg	108	111	112
Max power consumption/max current <sup>1</sup>	W/A	1170/2.2	1570/3.2	1850/3.4
Max operating temperature	°C [°F]	50 [122]		
Max operating pressure	Pa	50		
Motor insulation grade/protective class		F/IP55		
Noise level <sup>2</sup>	Db(a)	67.2	69.8	71.1

<sup>1</sup>50 Hz 400 V specification, 60 Hz available upon request, <sup>2</sup>Noise measure made according to ISO 3744

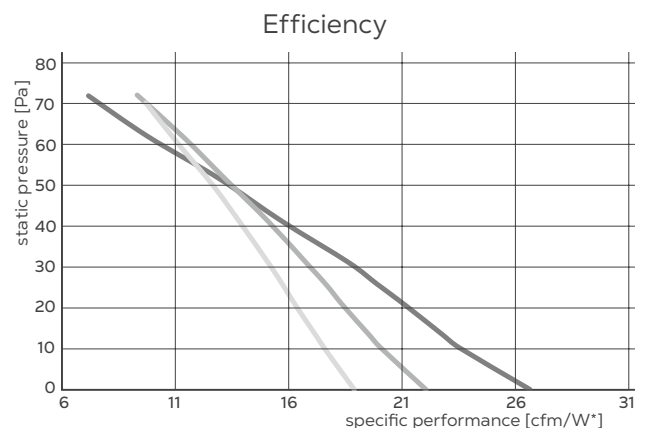
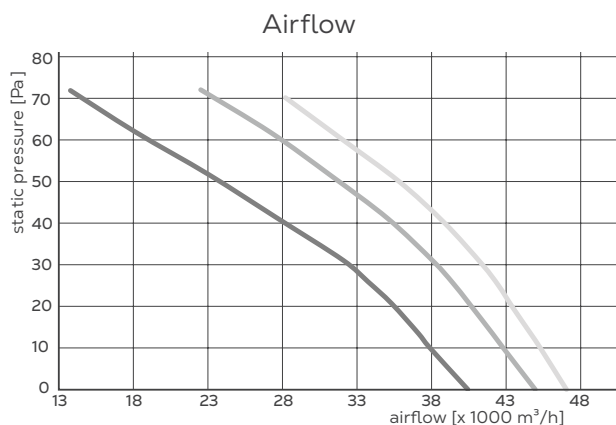

EC52 Belt 1.0	EC52 Belt 1.5	EC52 Belt 2.0
— IE1 1.0 hp	— IE1 1.5 hp	— IE1 2.0 hp

Airflow and efficiency tested in the test chamber in accordance with ANSI/AMCA 210/15 Standard, certified by BESS Lab. \*1 cfm/W = 1.7 (m<sup>3</sup>/h)/W

### Load capacity

	EC52 Belt 1.0/1.5/2.0	
	Unassembled	Assembled
40' HC container	220	39
13.6 m truck	-	41

Pyramidal mesh for installation below 2.7 m available upon request.

# Munters Euroemme EC52

## Erp

### Dimensions

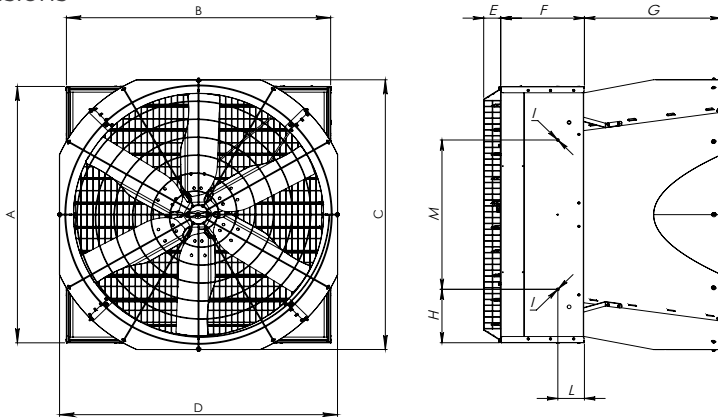

	EC52
A	1425 mm
B	1425 mm
C	1500 mm
D	1500 mm
E	95 mm
F	450 mm
G	740 mm
H	298 mm
I	M8
L	143 mm
M	830 mm

### Technical specifications

		EC52 Erp 1.5	EC52 Erp 2.0
Nominal power	hp [kW]	1.5 [1.1]	2.0 [1.5]
Propeller diameter	mm [inch]	1335 [52]	
Number of blades/material		6/M-Protect	
Number of shutter blades		10	
Motor/drive type		AC/Belt	
Weight of fully equipped fan	kg	112	
Max power consumption/max current <sup>1</sup>	W/A	1531/3	2410/4.6
Max operating temperature	°C [°F]	50 [122]	
Max operating pressure	Pa	90	
Motor insulation grade/protective class		F/IP55	
Noise level <sup>2</sup>	Db(a)	71.5	74.5

<sup>1</sup>50 Hz 400 V specification, 60 Hz available upon request, <sup>2</sup>Noise measure made according to ISO 3744

#### Airflow

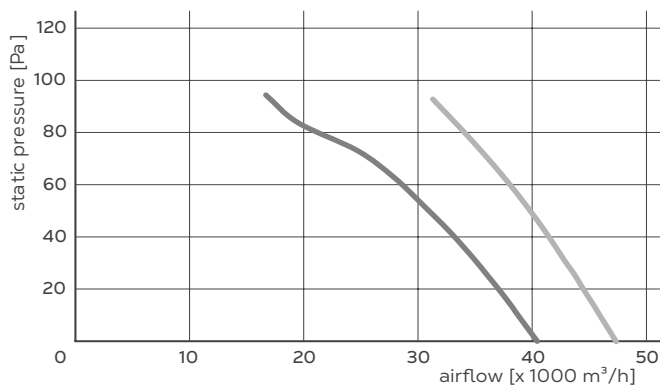

EC52 Erp 1.5

— IE3 1.5 hp

#### Efficiency

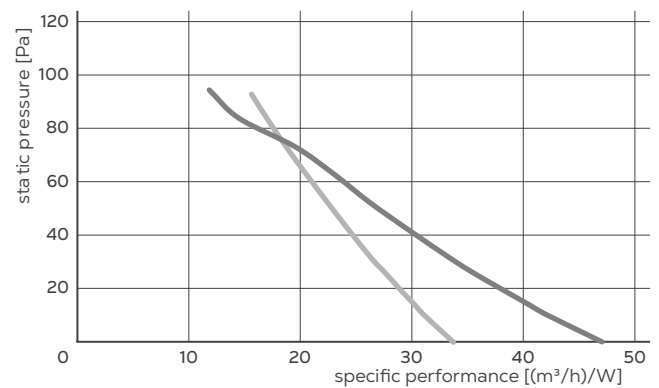

EC52 Erp 2.0

— IE3 2.0 hp

Airflow and efficiency tested in the test chamber in accordance with ANSI/AMCA 210/15 Standard, certified by BESS Lab.

### Load capacity

	EC52 Erp 1.5/2.0	
	Unassembled	Assembled
40' HC container	220	39
13.6 m truck	-	41

Pyramidal mesh for installation below 2.7 m available upon request.