

Munters Euroemme EM 50-52

Air extraction fans

EM50, introduced in the 1980s, is one of the most well-known box fans, recognized for its excellent performance in livestock farming (broiler, layer, swine, dairy) and greenhouse applications. EM52 builds on this legacy, offering the same reliability and efficiency.

Benefits

- Reliable, proven in the market for more than 40 years
- Superior durability with M-Protect coating
- Light and air draft reduction, when shutter is closed
- Energy efficient solution, the EM50 E-line version saves up to 50% on electricity costs
- Suited for tunnel ventilation



EM50 E-line

EM 50-52 are the ideal exhaust fans whenever extra high airflow capacity is required, even in high static pressure environments, thanks to their unique propeller shape that ensures full efficiency and reliability.

They feature extra strength against corrosion with housing, conveyor and shutter in M-Protect coated steel. For highly corrosive applications, the EMX50 version offers elements in stainless steel in addition to M-Protect.

The belt drive system enables low speed, to reduce energy consumption and noise, as well as to ensure a comfortable environment for animals and operators. The EM50 E-line model reduces power consumption by up to 50% compared to the same fan with AC motor, while enabling speed regulation.

The patented centrifugal system provides an energy efficient solution and powerful springs keep shutters tightly closed when the fan is not turned on, avoiding air leakage and blocking light.

As the market leader in ventilation solutions for more than 60 years, GrainProteinTech Climate Control & Air Treatment guarantees quality and is ISO 9001 certified.

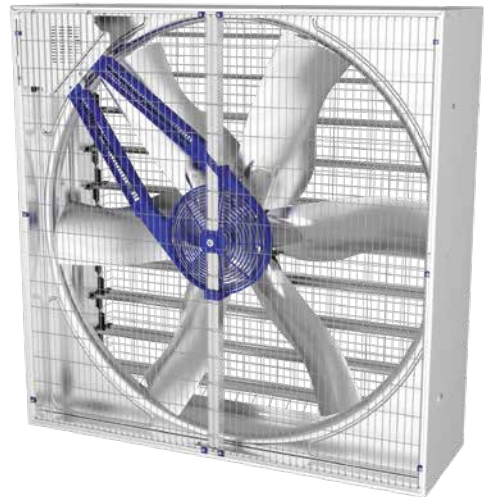

EM52



Proudly manufactured with 100% renewable energy in our plants in Italy

Future-proof your farm with EM50 Erp

Ready for the new European ErP Regulation.

The EM50 ErP-compliant model is engineered to meet EU efficiency requirements without compromising on the reliability and performance you trust.

- Full CE compliance: secure your farm with our certified fans.
- Enhanced performance: high airflow even at high static pressure.
- Seamless integration: a perfect fit for your existing farm layout.

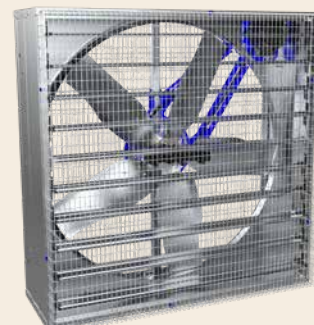

Munters Euroemme EM50

AC motor

Dimensions

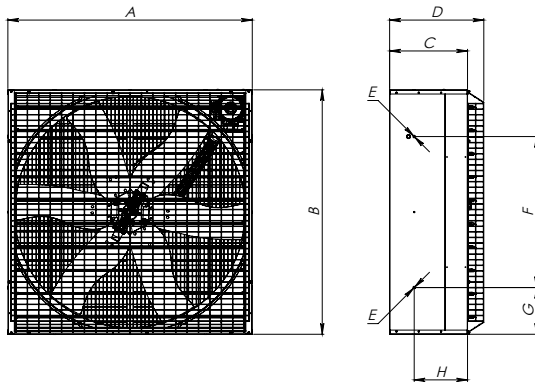

	EM50
A	1380 mm
B	1380 mm
C	450 mm
D	540 mm
E	M8
F	830 mm
G	275 mm
H	308 mm

Technical specifications

		EM50 Belt 1.0	EM50 Belt 1.5
Nominal power	hp [kW]	1.0 [0.75]	1.5 [1.1]
Propeller diameter	mm [inch]	1270 [50]	
Number of blades/material		6/M-Protect	
Number of shutter blades		10	
Motor/drive type		AC/Belt	
Weight of fully equipped fan	kg	84	86
Max power consumption/max current ¹	W/A	1200/2.1	1860/3.3
Max operating temperature	°C [°F]	50 [122]	
Max operating pressure	Pa	50	
Motor insulation grade/protective class		F/IP55	
Noise level ²	Db(a)	67.6	70.4

¹50 Hz 400 V specification, 60 Hz available upon request, ²Noise measure made according to ISO 3744

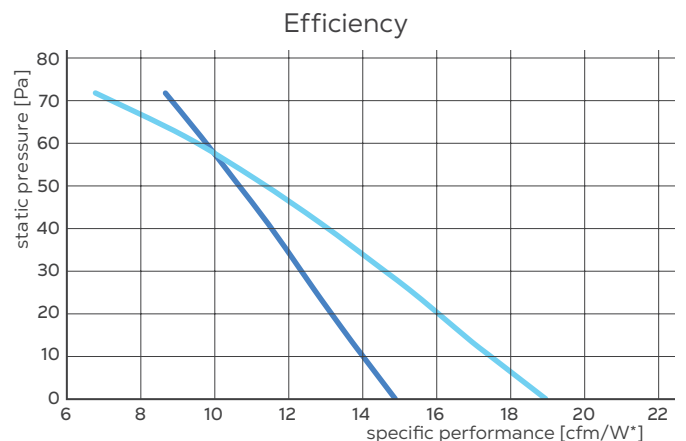
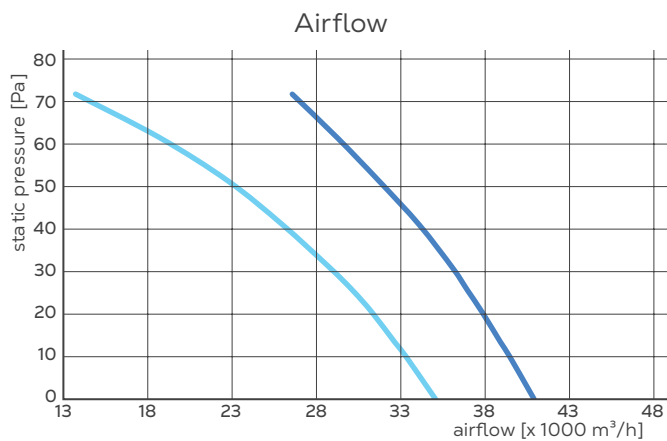

EM50 Belt 1.0

— IE1 1.0 hp

EM50 Belt 1.5

— IE1 1.5 hp

Airflow and efficiency tested in the test chamber in accordance with ANSI/AMCA 210/15 Standard, certified by BESS Lab. *1 cfm/W = 1.7 (m³/h)/W

Load capacity

	EM50 Belt 1.0/1.5	
	Unassembled	Assembled
40' HC container	300	57
13.6 m truck	-	65

Pyramidal mesh for installation below 2.7 m available upon request.

Munters Euroemme EM50

Erp

Dimensions

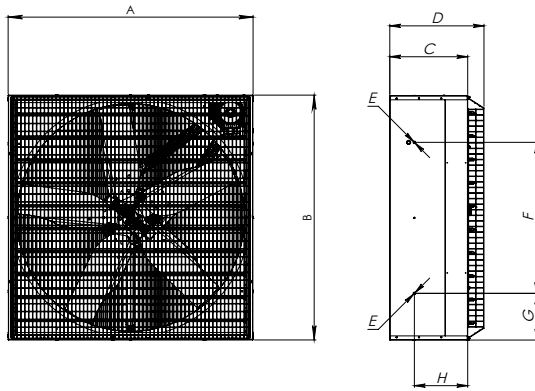

	EM50
A	1380 mm
B	1380 mm
C	450 mm
D	540 mm
E	M8
F	830 mm
G	275 mm
H	308 mm

Technical specifications

		EM50 Erp 1.5	EM50 Erp 2.0
Nominal power	hp [kW]	1.5 [1.1]	2.0 [1.5]
Propeller diameter	mm [inch]	1265 [50]	
Number of blades/material		5/M-Protect	
Number of shutter blades		10	
Motor/drive type		AC/Belt	
Weight of fully equipped fan	kg	91	93
Max power consumption/max current ¹	W/A	1285/3	2125/3.9
Max operating temperature	°C [°F]	50 [122]	
Max operating pressure	Pa	90	
Motor insulation grade/protective class		F/IP55	
Noise level ²	Db(a)	69.9	75.3

¹50 Hz 400 V specification, 60 Hz available upon request, ²Noise measure made according to ISO 3744

Airflow

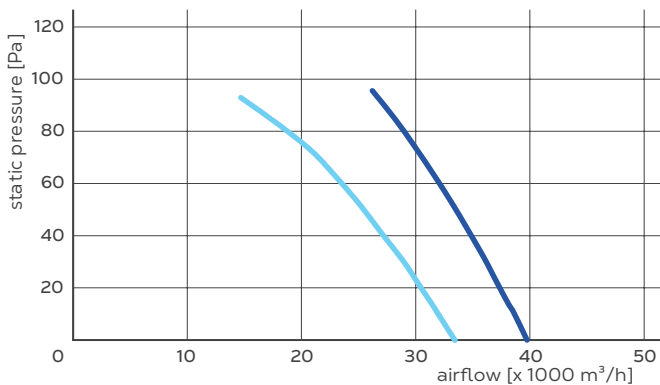

Efficiency

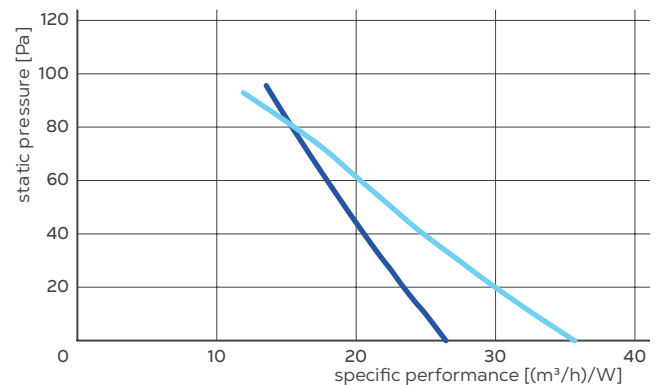

EM50 Erp 1.5

— IE4 1.5 hp

EM50 Erp 2.0

— IE4 2.0 hp

Airflow and efficiency tested in the test chamber in accordance with ANSI/AMCA 210/15 Standard, certified by BESS Lab.

Load capacity

	EM50 Erp 1.5/2.0	
	Unassembled	Assembled
40' HC container	270	57
13.6 m truck	-	65

Pyramidal mesh for installation below 2.7 m available upon request.

Munters Euroemme EM50

E-line

Dimensions

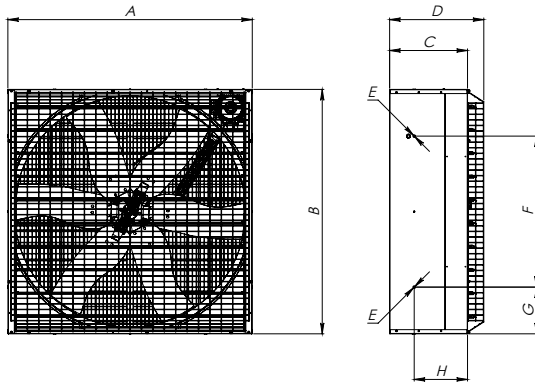

	EM50
A	1380 mm
B	1380 mm
C	450 mm
D	540 mm
E	M8
F	830 mm
G	275 mm
H	308 mm

Technical specifications

		EM50 E-line
Nominal power	hp [kW]	2.5 [1.8]
Propeller diameter	mm [inch]	1270 [50]
Number of blades/material		6/M-Protect
Number of shutter blades		10
Motor/drive type		EC/Belt
Weight of fully equipped fan	kg	87
Max power consumption/max current ¹	W/A	1600/3.2
Max operating temperature	°C [°F]	50 [122]
Max operating pressure	Pa	50
Motor insulation grade/protective class		H/IP66
Noise level ²	Db(a)	70.3

¹400 V specification, ²Noise measure made according to ISO 3744

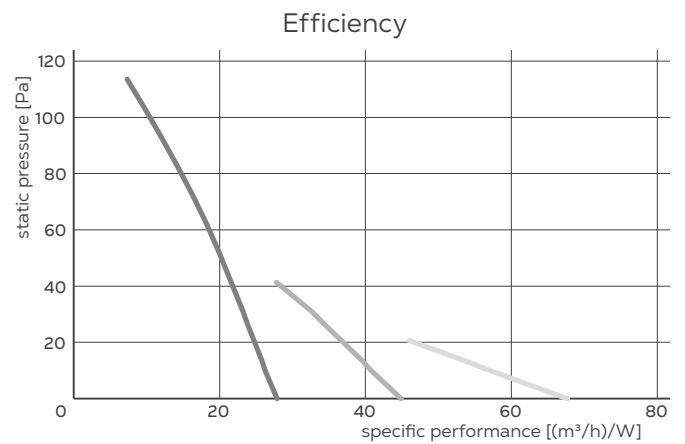
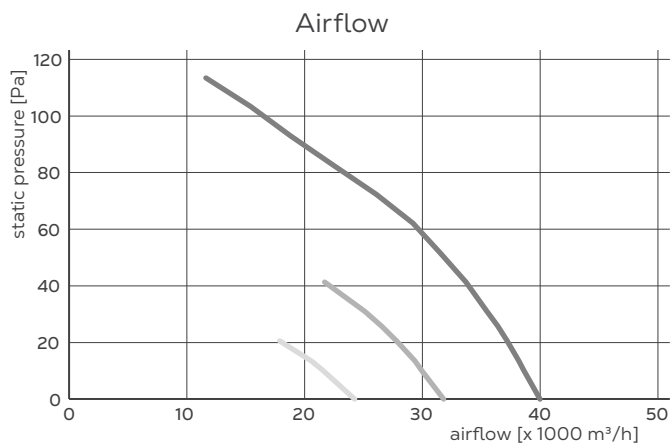

EM50 E-line

— 434 rpm — 330 rpm — 250 rpm

Airflow and efficiency tested in the test chamber in accordance with ANSI/AMCA 210/15 Standard, certified by BESS Lab.

Load capacity

	EM50 E-line	
	Unassembled	Assembled
40' HC container	250	57
13.6 m truck	-	65

Pyramidal mesh for installation below 2.7 m available upon request.

Munters Euroemme EM52

AC motor

Dimensions

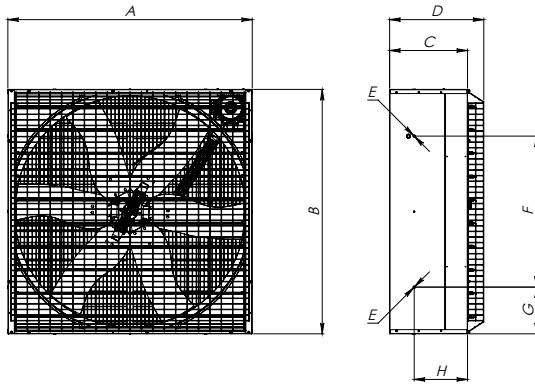

	EM52
A	1425 mm
B	1425 mm
C	455 mm
D	545 mm
E	M8
F	830 mm
G	298 mm
H	310 mm

Technical specifications

		EM52
Nominal power	hp [kW]	2.0 [1.5]
Propeller diameter	mm [inch]	1334 [52]
Number of blades/material		6/M-Protect
Number of shutter blades		10
Motor/drive type		AC/Belt
Weight of fully equipped fan	kg	90
Max power consumption/max current ¹	W/A	1770/3.5
Max operating temperature	°C [°F]	50 [122]
Max operating pressure	Pa	100
Motor insulation grade/protective class		F/IP55
Noise level ²	Db(a)	70.3

¹50 Hz 400 V specification, 60 Hz available upon request, ²Noise measure made according to ISO 3744

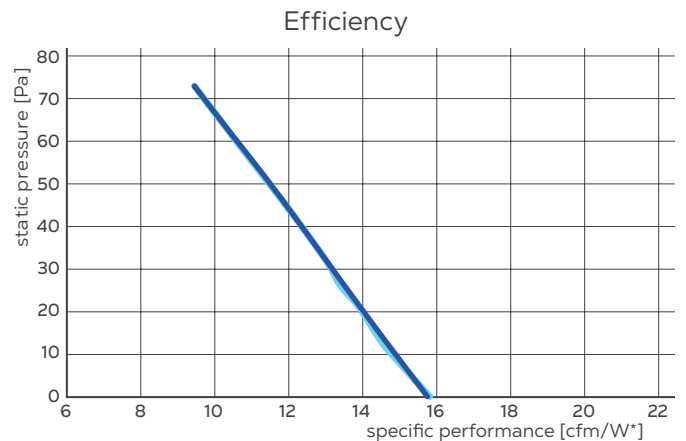
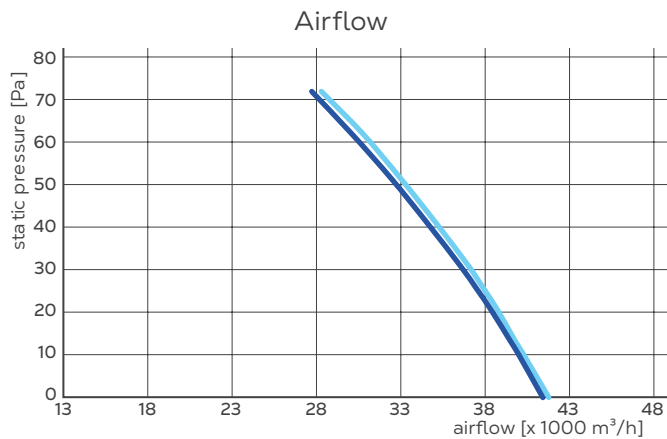

EM52

— IE3 2.0 hp

— IE1 2.0 hp

Airflow and efficiency tested in the test chamber in accordance with ANSI/AMCA 210/15 Standard, certified by BESS Lab. *1 cfm/W = 1.7 (m³/h)/W

Load capacity

	EM52	
	Unassembled	Assembled
40' HC container	300	57
13.6 m truck	-	64

Pyramidal mesh for installation below 2.7 m available upon request.